



ASPOWER

深圳欧陆通电子股份有限公司

深圳欧陆通电子股份有限公司  
SHENZHENHONOR ELECTRONIC CO., LTD

ASPOWER

Electrical Specification

Model Name

U1A-P10650-DRB

Version

S0

Release Date

2021/02/04

# Electrical Specification

(With +12V & +5VSB output (SGCC) Optimize)

Drawn: 王宝玲

Design (EE): 卢展浩

Design (ME): 林东辉

Design (FE): 吴志江

Approve: 李新林





ASPOWER

深圳欧陆通电子股份有限公司

# Contents

<b>17.0 DELETED SAFETY CERTIFICATION</b> .....	错误!未定义书签。
<b>2018/07/18</b> .....	错误!未定义书签。
<b>1.0 SCOPE</b> .....	<b>5</b>
<b>2.0 INPUT PARAMETER</b> .....	<b>5</b>
2.1 INPUT VOLTAGE/INPUT CURRENT/FREQUENCY .....	5
2.2 INRUSH CURRENT .....	5
2.3 EFFICIENCY (FOR MODULE).....	6
2.4 HOLD UP TIME (AC & HVDC).....	6
2.5 AC/HVDC LINE DROPOUT .....	6
2.6 POWER FACTOR .....	6
2.7 SURGE AND SAG.....	7
<b>3.0 OUTPUT PARAMETER</b> .....	<b>7</b>
3.1 OUTPUT CURRENT .....	7
3.2 VOLTAGE REGULATION .....	8
3.3 RIPPLE & NOISE .....	8
3.4 TIMING.....	8
3.5 OVERSHOOT.....	9
3.6 DYNAMIC .....	10
3.7 CAPACITIVE LOADING.....	10
3.8 CURRENT SHARING AND REDUNDANCY.....	10
3.9 PWOK SIGNAL .....	11
<b>4.0 PROTECTION</b> .....	<b>11</b>
4.1 OVER VOLTAGE PROTECTION (OVP).....	11
4.2 UNDER VOLTAGE PROTECTION (UVP) .....	11
4.3 OVER TEMPERATURE PROTECTION (OTP) .....	11
4.4 SHORT CIRCUIT PROTECTION (SCP) .....	11
4.5 OVER CURRENT PROTECTION (OCP) .....	12
4.6 WARNING TYPE .....	12
4.7 ALARM SIGNAL.....	12
<b>5.0 OPERATE ENVIRONMENT</b> .....	<b>12</b>
5.1 OPERATE TEMPERATURE .....	12
5.2 STORAGE TEMPERATURE .....	12
5.3 OPERATE HUMIDITY .....	12
5.4 STORAGE HUMIDITY .....	13
5.5 OPERATE ALTITUDE.....	13
5.6 STORAGE ALTITUDE.....	13
5.7 COLD START .....	13
<b>6.0 SAFETY</b> .....	<b>13</b>
6.1 SAFETY CERTIFICATION .....	13
6.2 HI-POT .....	13
6.3 GROUNDING IMPEDANCE TEST .....	13
6.4 LEAKAGE CURRENT .....	13
6.5 SMOKELESS.....	14
6.6 WARNING.....	14
<b>7.0 OUTLINE STRUCTURE</b> .....	<b>14</b>
7.1 OUTLINE DIMENSION .....	14



**ASPOWER**

深圳欧陆通电子股份有限公司

---

7.2 GOLDEN FINGER .....	14
<b>8.0 RESTRICTED SUBSTANCE .....</b>	<b>15</b>
8.1 ROHS .....	15
8.2 RESTRICTED SUBSTANCE .....	15
<b>9.0 EMC.....</b>	<b>16</b>
9.1 LIGHTING .....	16
9.2 EMI .....	16
9.3 ESD .....	17
<b>10.0 PART CONTROL REQUIREMENTS .....</b>	<b>18</b>
<b>11.0 MECHANICAL PERFORMANCE.....</b>	<b>18</b>
<b>12.0 MTBF .....</b>	<b>20</b>
<b>13.0 HALT.....</b>	错误!未定义书签。
<b>14.0 THERMAL SHOCK TEST .....</b>	错误!未定义书签。
<b>15.0 PACKAGE .....</b>	<b>20</b>
15.1 OUTLINE DIAGRAM OF CARTON.....	20
15.2 SIDE LABEL.....	21
15.3 FRONT LABEL .....	22
<b>16.0 STRESS/COMPONENT DE-RATING .....</b>	<b>22</b>
<b>17.0 SOFTWARE .....</b>	<b>23</b>
17.1 PMBUS COMMUNICATION .....	23
17.2 SOFTWARE DATA FORMAT.....	24
17.3 STATUS COMMAND .....	24
17.4 SUPPORTED COMMAND.....	27



## 1.0 SCOPE

The specification defines the key characteristics for the power supply, which is intended for worldwide use in IT equipment such as server application. Output connector type is the gold finger, and output ports include +12V and +5VSB. The power supply has a fan for air-cooling. The maximum output power is 650W.

## 2.0 INPUT PARAMETER

### 2.1 Input Voltage/Input Current/Frequency

The power supply shall operate within input limited voltage range as defined in Table 1, which includes the limited value of input current, input voltage, working frequency. The power supply shall be capable of start up from min load to max load at line input as low as 90VAC.

**Table1.**

	Min	Rated	Max	Units
AC input voltage	90	100~127	264	VAC
		200~240		VAC
Frequency	47	50/60	63	Hz
HVDC input voltage	180	200~340	380	VDC
Input current	<8A@100~240VAC @full load			

Note:

1. For 360V-380V the PSU only meet turn on at min load and max load

### 2.2 Inrush Current

Cold start at normal input voltage at 25°C, when input power is applied to the power supply and any initial inrush current surge or spike longer than 1ms shall not exceed 50A peak @230Vac. Inrush current difference between line and neutral is under 0.1A per half cycle of input current and/or the phase difference between line and neutral is less than +/-20 degrees during each AC input voltage half-cycle.



The inrush shall be less than the ratings of the critical components. Any inrush current of the AC line shall not cause damage to the power supply. Surge current does not contain the current spike due to X-Cap and Y-Cap.

### 2.3 Efficiency (for module)

The power supply module achieves the 80 plus level by testing at the 230Vac/50Hz, 18degC-27degC ambient temperature and the loading condition show in Table 2. Efficiency testing delay time should be 30min after running the PSU, and so that the PSU in under steady state. This efficiency test refers to 80Plus Test Protocol “Generalized Test Protocol for Calculating the Energy Efficiency of Internal Ac-Dc and Dc-Dc Power Supplies Revision 6.7”.

Table2.

Load	+12V	+5Vsb	EFF
20%	10.6A	0.5A	>87%
50%	26.6A	1.2A	>90%
100%	53.2A	2.5A	>87%

### 2.4 Hold up Time (AC & HVDC)

Hold up time is defined length of time from AC input drops to 0V to +12V dropping out of voltage regulation range at any phase of the AC or HVDC input, the power supply should meet dynamic voltage range.

1. Hold up time +12Vout>=9ms@80% load (90~264VAC/180~360VDC)

### 2.5 AC/HVDC Line Dropout

AC/HVDC line dropout is the condition when AC/HVDC input voltage drops to 0V at any phase of the AC/HVDC line for any length of time. During an AC/HVDC dropout of 9ms or less than the power supply’s hold up time shall meet voltage regulation in the rated load and half load at all AC input voltages.

An AC or HVDC line dropout of 9ms or less at 80% load shall not cause malfunction of control signals or protection circuit trip. If the AC or HVDC dropout lasts longer than 9ms the power supply shall recover and meet all turn on requirements.

Any dropout of the AC/HVDC line shall not cause damage to the power supply.

### 2.6 Power Factor



The power supply must meet the power factor requirements stated in the Energy Star Program Requirement for Computer Servers V2.0. The power factor shall meet the requirement as below table at 230Vac/50Hz and 115Vac/60Hz input voltage condition.

**Table3.**

Load	10% Load	20% Load	50% Load	100% Load
PF	>0.65	> 0.80	> 0.90	> 0.95

## 2.7 Surge and Sag

The dynamic conditions of AC line are defined as sag and surge. Sag is mainly drop to below normal voltage, surge refers to the input voltage rising above the normal range, the PSU shall meet the requirements under the following AC line sag and surge conditions.

**Table4. Surge and Sag Test Condition**

Duration	Surge/Sag	Input Voltage	Frequency	Performance Criteria
500ms	10%	220/110VAC 240VDC	50/60Hz	No loss of function or performance
0 to 1/2 AC cycle	30%	220/110VAC 240VDC	50/60Hz	Loss of function acceptable, power supply can turn on automatically
=1/2 AC cycle	30%	220/110VAC 240VDC	50/60Hz	Loss of function acceptable, power supply can turn on automatically
>1/2 AC cycle	>30%	220/110VAC 240VDC	50/60Hz	Loss of function acceptable, power supply can turn on automatically

## 3.0 OUTPUT PARAMETER

### 3.1 Output Current

The following table defines the output current ratings. The combined output power of all outputs shall not exceed the rated output power (650W). The power supply shall meet both static, dynamic voltage regulation and timing requirements for all loading conditions defined in specification.

**Table5.**

Output Voltage	Min Current	Max current
+12V	0.3A	54A
+5Vsb	0A	3A

Note:

1. The continuous total output power is 650W max.

### 3.2 Voltage Regulation

The power supply output voltages must stay within the following voltage limits shown in below table when operating at steady state, dynamic loading conditions. All outputs are measured with reference to the return remote sense (ReturnS) signal.

**Table6.**

Output Voltage	Min	Rated	Max	Tolerance
+12V	11.4V	12.0V	12.6V	+/-5%
+5Vsb	4.75V	5.0V	5.25V	+/-5%

### 3.3 Ripple & Noise

**Table7.**

Output voltage	Ripple & noise
+12V	<120mV
+5Vsb	<50mV

Note:

1. The ripple & noise is measured over a bandwidth of 20MHz at the power supply output connectors. A 10 $\mu$ F Electrolytic capacitor in parallel with a 0.1 $\mu$ F ceramic capacitor is placed at the point of measurement.

### 3.4 Timing

These timing requirements for power supply operation include alone module's output and multi modules' outputs. All outputs shall rise and fall monotonically. In additional, PSU timing must meet the requirement of mother board. The timing characteristics must be evaluated and verified when in design stage and system test stage.

**Table8.**

Item	Description	Min	Max	Units
------	-------------	-----	-----	-------





ASPOWER

深圳欧陆通电子股份有限公司

Tvout_rise	Output voltage rise from 10% to 90% time.	1	20	ms
Tsb_on_delay	Delay from AC being applied to +5Vsb being within regulation.		1000	ms
Tac_on_delay	Delay from AC being applied to +12V being within regulation.		2000	ms
Tsb_vout	Delay from +5Vsb being in regulation to +12V being in regulation at AC turn on.	50	1000	ms
Tpson_on_delay	Delay from PSON active to output voltages being within regulation limits.	5	500	ms
Tpwok_on	Delay from output voltages within regulation limits to PWOK asserted at turn on.	100	500	ms
Tvout_holdup	Time +12V output stay within regulation after loss of AC (80% Full Load).	9		ms
Tpwok_holdup	Delay from loss of AC to de-assertion of PWOK.	6		ms
Tpwok_off	Delay from PWOK de-asserted to output voltages dropping out of regulation limits.	1.5		ms

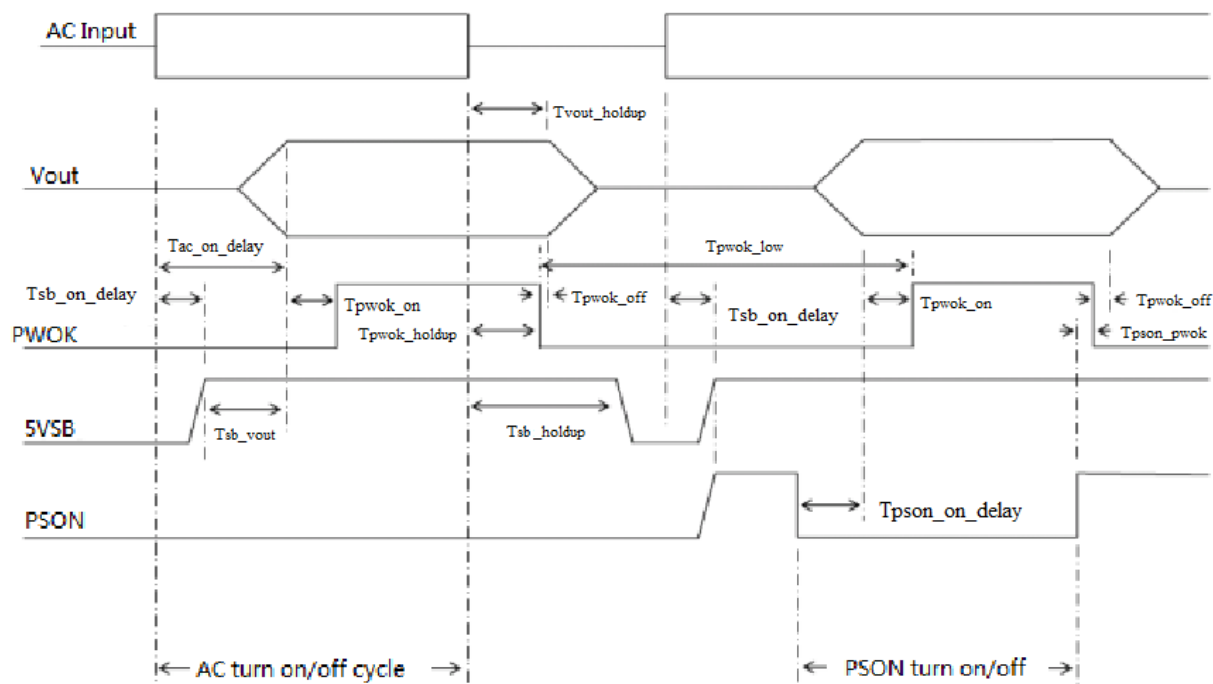

### 3.5 Overshoot



Output voltage overshoot is less than 10% with 30% load step and any input voltage, the output rising up waveform should be kept flat and smoothly.

Table9.

Output Voltage	Overshoot (Max)
+12V	13.2V

### 3.6 Dynamic

The output voltage shall remain within limits specified for the step loading, slew rate, and capacitive loading in below table.

The load transient repetition rate shall be tested between 50Hz to 5KHz at duty cycles rang from10%-90%. The test shall be at least in 50 Hz/1KHz/5KHz condition. The output current transient repetition rate is only a test specification.

Table10.

Output Voltage	Transient Step (A) Percent of Rated Current	Slew rate (A/us)	Frequency (Hz)	Cap (uF)
+12V	30%	1.0	50-5K	4700uF

### 3.7 Capacitive Loading

The power supply shall be stable and meet all requirements with the following capacitive loading range. The PSU is not damaged include normal turn on timing, running under all loading conditions.

Table11.

Output Voltage	+12V	+5Vsb
Capacitive loading (uF)	10000	10000

### 3.8 Current Sharing and Redundancy

This power supply has redundant function, the module of this supply must be able to load share in parallel and operate in a hot-swap. The output current sharing should within ±10% when half and full load.

Table12.

Load Condition	50%	100%



Current Sharing Degree	<10%	<10%
------------------------	------	------

### 3.9 PWOK Signal

PWOK is a power OK signal and it will be pulled high, when the power supply indicates all outputs are within the regulation. When +12V, output have a fault, the PWOK will be de-asserted to a low state

## 4.0 PROTECTION

To operation safely and reliably, inside circuit in the power supply should have necessary protection function for various abnormal situations, include OCP, OVP, OTP, input UVP and short. The main output shall shut down and latch off under protection mode. When the fault or protection is removed, power supply must be able to turn on by PSON/OFF re-cycles. +5Vsb output is auto recovery when fault condition removed.

### 4.1 Over Voltage Protection (OVP)

When +12V output OVP occurred, the power supply should shut down and latch off, power supply must be able to turn on by PSON/OFF re-cycles.

The OVP range is shown in below table.

**Table13.**

Voltage	Min(V)	Max(V)
+12V	13.0	15.0

### 4.2 Under Voltage Protection (UVP)

The UVP range is shown in below table.

**Table14.**

Voltage	Min(V)	Max(V)
+12V	8	10

### 4.3 Over Temperature Protection (OTP)

The power supply will be protected against over temperature conditions caused by loss of fan cooling or excessive ambient temperature. In an OTP condition the PSU will shut down and latch-off. The ambient OTP is 55+/-4°C.

### 4.4 Short Circuit Protection (SCP)



The power supply shall shut down and output is under skip mode, when main output is under shorten mode (impedance less than 0.1ohm). The power supply should be under protection mode to keep component safe, whatever the output is shorten before turn on or shorten after turn on. The main output voltage shall shut down and latch off, and power supply must be able to turn on by PSON/OFF re-cycles.

#### 4.5 Over Current Protection (OCP)

**Table15. OCP Limited Table**

Output	Min	Max
+12V	59A	69A

Note:

1. The output voltage will be latch off when any output of power supply is triggered over current protection. When the OCP conditions removed, +12V will be recovery by recycling PS/ON.

#### 4.6 Warning Type

**Table16.**

Status		Module LED
Normal		green
Fault	Only +5Vsb	yellow
	No +5Vsb	off
Reset		Yellow/off

#### 4.7 Alarm Signal

When alarm pin is low, it indicates the power supply has a fault event.

### 5.0 OPERATE ENVIRONMENT

#### 5.1 Operate Temperature

Operate temperature: 0°C to +50°C.

#### 5.2 Storage Temperature

Storage temperature: -20°C to +70°C.

#### 5.3 Operate Humidity

Operate Humidity (non-condensing): 10% to 90%.

ISO 表单编号: OLTIPC-SOPRD-007-010A0 保存期限 10 年



## 5.4 Storage Humidity

Storage Humidity (non-condensing): 5% to 95%.

## 5.5 Operate Altitude

Operate Altitude: 0 to 5000m.

## 5.6 Storage Altitude

Storage Altitude: 0 to 10000m.

## 5.7 Cold Start

The power supply shall be able to turn on at -10degC.

## 6.0 SAFETY

### 6.1 Safety Certification

The power supply must meet to the safety standard listed following.

CCC: Certificate for China compulsory product certification.

(GB4943-2001, GB9254-1998, GB17625.1-2003)

CE: (EN55022:2010, EN55024:2010, EN61000-3-2:2014, EN61000-3-3:2013)

FCC: (FCC PART 15 Subpart B)

### 6.2 Hi-pot

Primary to secondary, HI-POT Withstand voltage: 3000Vac, 60s, leakage current <10mA; 4242Vdc, 60s, leakage current <0.5mA (for PCBA) .

Primary to GND, HI-POT Withstand voltage: 1500Vac, 60s, leakage current <10mA; 2121Vdc, 60s, leakage current <0.5mA.

### 6.3 Grounding Impedance Test

Grounding impedance test using grounding current 32A for 60s and the impedance is less than 100mohm.

### 6.4 Leakage Current

In order to ensure that the leakage current of the power supply case not cause leakage damage to the human body, after inserting the AC power, the leakage current of the power supply should meet the requirements of safety. Under 264Vac/60Hz conditions to be less than 3.5mA test with customer system.



ASPOWER

深圳欧陆通电子股份有限公司

## 6.5 Smokeless

Parts failure in the power supply shall not have smoke and flame. And it is necessary to put a fuse in the front of DC-DC conversion circuit or equivalent circuit to prevent smoke and diffusion. Parts failure will trigger the fuse open. All power components are not limited in safety components, but it should be required to verify in the smoke-less testing.

## 6.6 Warning

1. The PSU must have insulation protection.
2. To avoid electric shock and injury, the PSU must not be energized before finishing installation.
3. This PSU only allows professional maintenance.

## 7.0 OUTLINE STRUCTURE

### 7.1 Outline dimension:

Length: 263mm include gold finger length

Width: 48mm

Thickness: 40mm

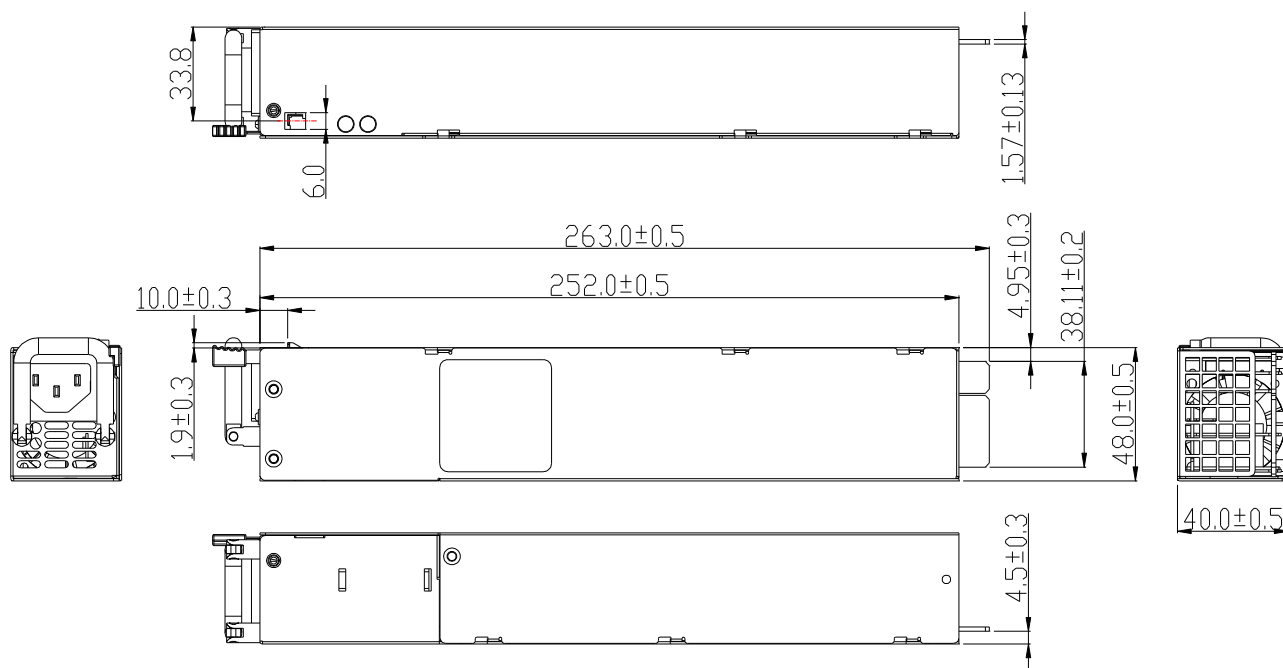



### 7.2 Golden Finger

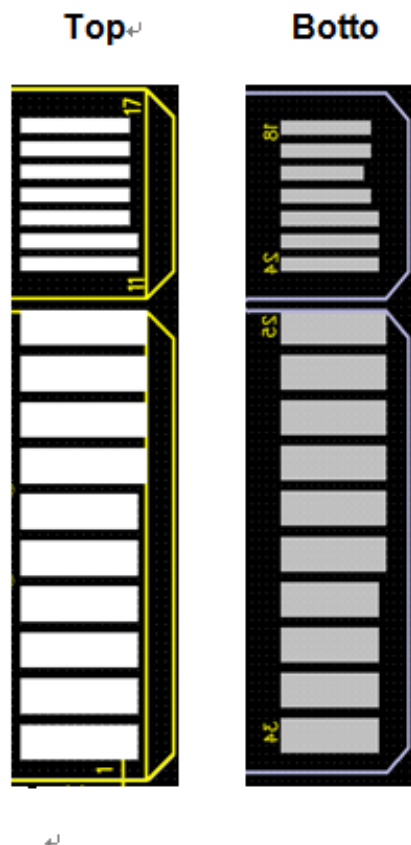

PIN↕	NAME↕	PIN↕	NAME↕
1↕	+12V↕	18↕	Alarm↕
2↕		19↕	PGO↕
3↕		20↕	PS/ON↕
4↕		21↕	+12VS↕
5↕		22↕	5VSB↕
6↕	23↕		
7↕	GND↕	24↕	GND↕
8↕		25↕	
9↕		26↕	
10↕		27↕	
11↕	5VSB↕	28↕	↕
12↕		29↕	
13↕	+12VBUS↕	30↕	+12V↕
14↕	A/D5↕	31↕	
15↕	SCL1↕	32↕	
16↕	SDA1↕	33↕	
17↕	Protection↕	34↕	↕

## 8.0 RESTRICTED SUBSTANCE

### 8.1 ROHS

Power supply must meet be Rohs6 compliant including the component, PCB, soldering material, case, wire, and so on.

### 8.2 Restricted Substance

Recycled Plastics: Post-consumer recycled content plastics to constitute have a minimum of 4% of total supplier plastic purchases.



Packaging: Minimum 50% total recycled content, including 30% post-consumer recycled content for corrugated materials. Corrugated – min. 50% total recycled content, min. 30% post-consumer content.

Minimum 50% of total recycled content by weight is across all new systems for cushions

## 9.0 EMC

### 9.1 Lighting

Lightning test meet the IEC61000-4-4 electric fast transient standard, withstand voltage: +/- 2KV. Performance criterion: A.

**Table17.**

Lighting	Withstand requirement
EFT	±2KV

Surge defined in IEC61000-4-5 standard, including the upper limit of the standard including phase angle: 0 degree, 90 degree, 180 degree, 270 degree. It is suitable for input AC/DC power supply of four combinations (L1-L2, L1-PE, L1&L2-PE, and L2-PE). Performance criterion: B.

The requirement for surge is listed in the table as below.

**Table18.**

Lighting	Common	Different
Surge	±2KV	±1KV
Resistance	12ohm	2ohm

A. Equipment can work in the specified conditions.

B. Test equipment temporary performance decline, loss of function or reset phenomenon, but it can be recovery itself.

C. Equipment has temporary performance decline or loss of function, and it is restored by operator intervention or system.

D. Equipment has non recoverable performance degradation or loss of function due to component damage, software affected or data loss.

### 9.2 EMI





Electromagnetic interference (EMI) project basic requirements: radiation interference (RE) and conduction interference (CE), and it shall meet the standard requirements of Class B with 6dB Margin (In system chassis). Criterion refers to EN 55022 standards.

**Table19. Conduction Performance Requirement**

Item	Frequency Segment	Reference Standard	Note
Conduction interference	150KHz~30MHz	EN 55022	115V/60Hz, 230Vac/50Hz

**Table20. Conduction CLASS B Standard Limitation**

Freq (MHz)	Limitation (dBuV/m)	
	QP	AVG
0.15-0.50	66~56	56~46
0.50-5	56	46
5-30	60	50

**Table21. Radiation Index Requirements**

Item	Frequency Segment	Reference Standard	Note
Radiation Interference	30MHz~1GHz	EN 55022	115V/60Hz,230Vac/50Hz

**Table22. Radiation CLASS B Standard Limitation**

FREQ	Limitation (dBuV/m)
30-230MHz	40
230-1000MHz	47

### 9.3 ESD

Power supply should be able to meet the IEC61000-4-2 ESD standard, the need to meet the level 4 requirements of contact 8KV, isolation 15KV standard. It should not have power product shutdown, signal drop, product burning and other undesirable phenomena. Performance criterion: B

Performance criterion:

- A. Equipment can work in the specified conditions.
- B. Test equipment temporary performance decline, loss of function or reset phenomenon, but it can be recovery itself.
- C. Equipment has temporary performance decline or loss of function, and it is restored by operator intervention or system.



D. Equipment has non recoverable performance degradation or loss of function due to component damage, software affected or data loss.

Electrostatic discharge experiment is mainly simulating the condition as below

Table23. ESD Degree of Severity

ESD Grade	Contact	Air
3	4KV	8KV

### 10.0 PART CONTROL REQUIREMENTS

1. All current limiting devices shall have UL, TUV or VDE certification and shall be identified as applications in which the device complies with IEC60950.

2. All printed circuit board ratings shall meet UL94V - 0 and those from UL certified PCB manufacturers.

3. All joints shall pass UL certification and UL flame retardant rating UL94V-0.

4. All wiring harness shall be from UL certified wiring harness manufacturer. SELV (Safety Extra Low Voltage) cable is rated at minimum 80V, 130degC.

5. Product safety labels must be printed with UL certified labels and ribbons. In addition labels can be purchased from UL label manufacturers for approval.

6. The product must have the correct regulatory marks to support the certification specified in this document.

### 11.0 MECHANICAL PERFORMANCE

Mechanical vibration experiment is mainly to simulate the product vibration experiment in the work and transport process, the purpose is to test whether the product can meet certain specifications of vibration intensity, the main test items include:

1. Work random vibration.
2. Work shock.
3. Packaging random vibration.

Table24.

NO	Experiment Item	Sample	Standard	Parameter	Criterion
1	work random	≥3	IPC9592A-2010	ASD: 20~1000Hz: 0.04g <sup>2</sup> /Hz;	Power supply voltage is Within the



	vibration		IEC60068-2-64	1000~2000Hz: 6db/oct; 2000Hz: 0.01g2/Hz. About 8Grms. 3 axial, each axial at least 10min. Test process sample power on, normal input voltage, no load. During the test, each power output and signal output should be monitored continuously. The monitoring period should be less than 1ms.	specification limits during the test.
2	work shock	≥3	IPC9592A-2010 IEC60068-2-27	Half sine wave, 16ms, at least 30g. 3 axial, each axial 3 times. During the test, each power output and signal output should be monitored continuously. The monitoring period should be less than 1ms.	Power supply voltage is within the specification limits during the test.
3	packaging random vibration	≥3	IPC9592A-2010 IEC60068-2-64	ASD: 5~1000Hz: 0.05g2/Hz; 1000~2000Hz: 6db/oct; 2000Hz: 0.0125g2/Hz. About 9Grms, 3 axial, each axial at least 10min. Each PSU should have independent packaging follow normal delivery.	After the test, product should be inspected. Allows minor damage without affecting appearance, installation, or function. Connector pins are not allowed to bend, switch damage, handle damage. Label



					<p>readability is poor, metal deformation or bending.</p> <p>All equipment through functional testing. Test shipment packaging damage degree does not make judgment requirements.</p>
--	--	--	--	--	---

### 12.0 MTBF

Quantitative reliability (Quantitative) performance requirements: MTBF (MTBF Mean Time Between Critical Failure), according to the Bellcore standard : Telcordia Technologies SR-332 (Method I Case 3), the PSU operates continuously under 25degC condition, 230V/50HZ under max load, and MTBF is more than 100000 hours, the testing process should not be interrupted.

Life time  $\geq$  5 years at 25°C ambient @100% load under 230Vac/50Hz .

**Table25.**

Input Voltage	Load	MTBF
230VAC/50Hz	+12V/53.2A, +5VSB/2.5A	100000hours

### 13.0 PACKAGE

Power supply module package shall be the Anti-ESD bag to avoid power supply damage in shipment.

#### 13.1 Outline Diagram of Carton



ASPOWER

深圳欧陆通电子股份有限公司

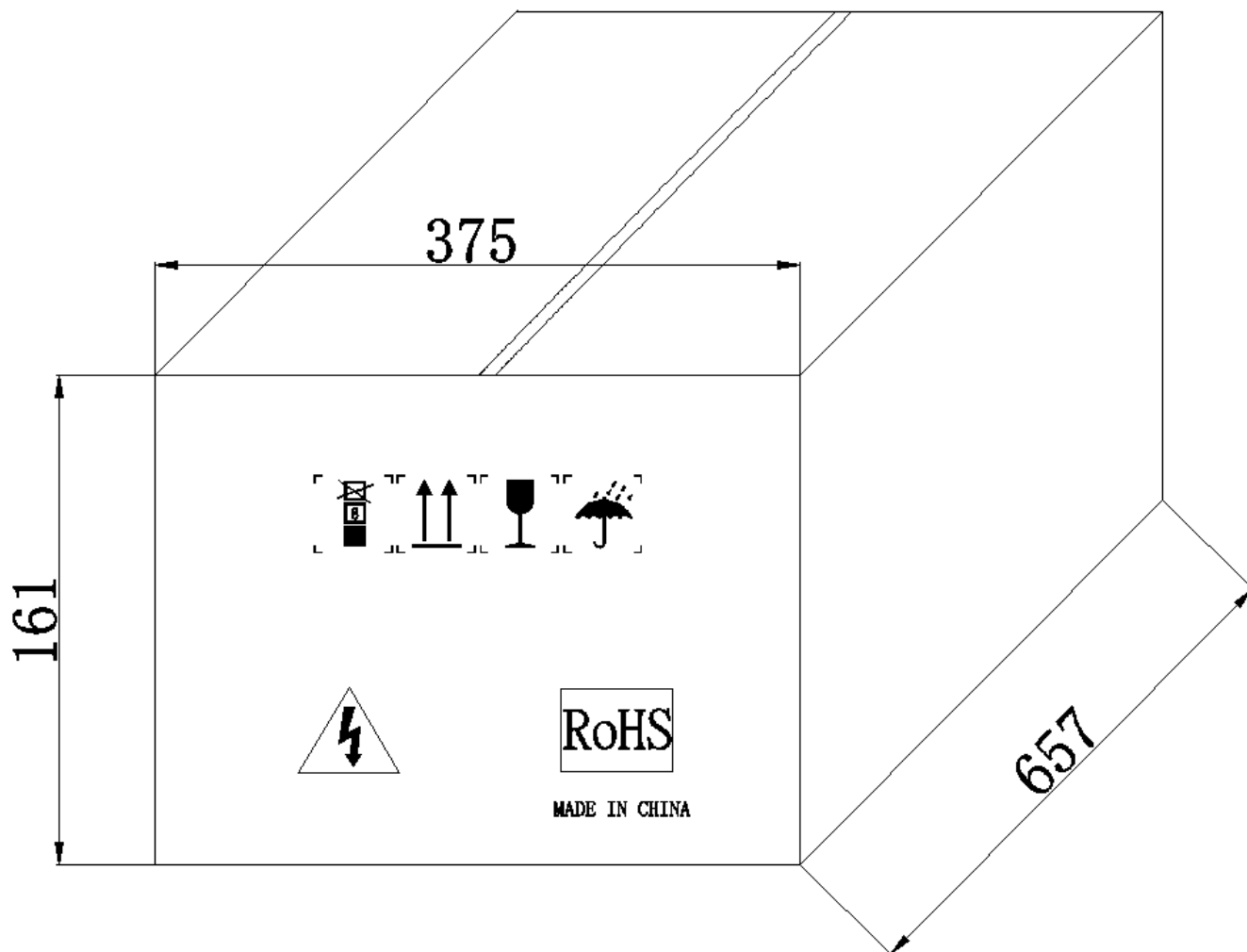

Note:

Material: K=K, five layers of corrugated paper.

### 13.2 Side Label

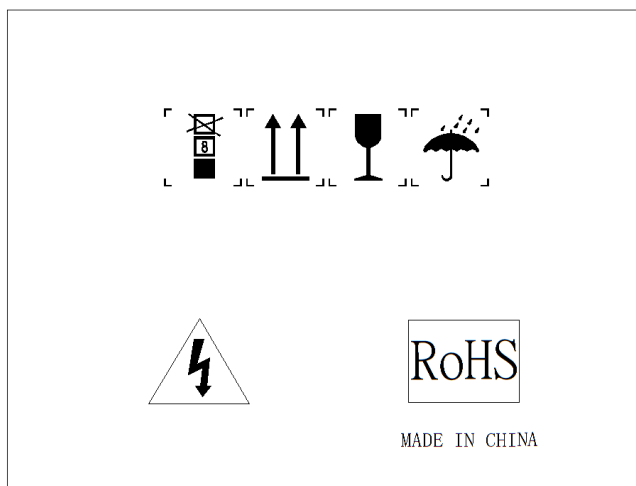



ASPOWER

深圳欧陆通电子股份有限公司

### 13.3 Front Label

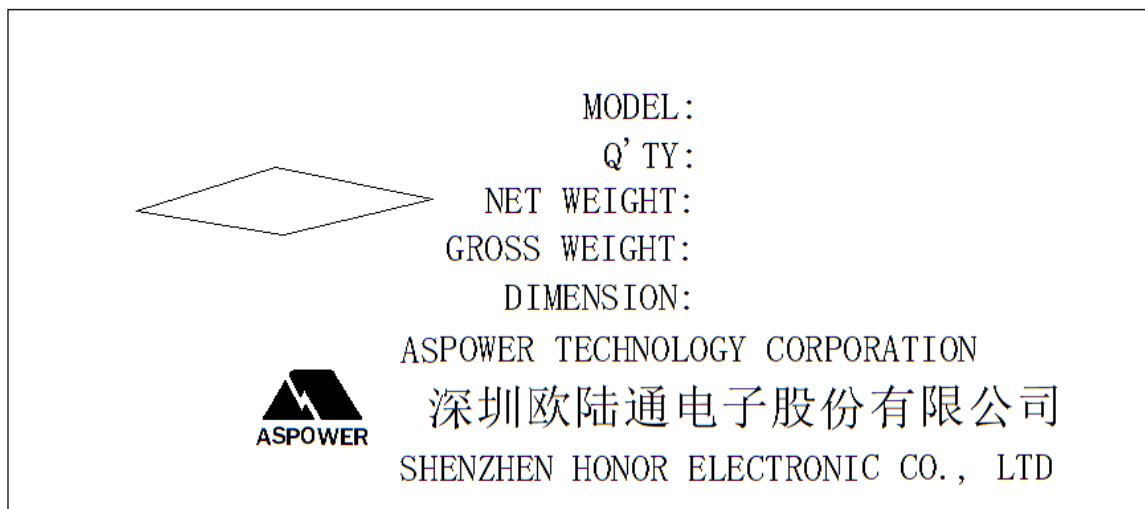

### 14.0 STRESS/COMPONENT DE-RATING

The following component de-rating requirements shall be followed:

1. The semiconductor junction temperature at all loads condition, all input voltage range, and ambient of 50 °C shall not exceed 90% rated specification.

2. Capacitor: ripple current: 90% of rated specification at frequency and temperature.

Voltage: 90% of the rated specification. Bulk cap voltage de-rating  $\leq 90\%$  of the rated specification, if not meet this limited, Manufacturers need to provide guarantee letter.

3. Resistor: The power of resistor's de-rating  $\leq 65\%$  of the rated specification whatever is ambient or high 50 °C condition and all of input voltage range.

4. Static voltage/power/current de-rating of all components  $\leq 90\%$  of the rated specification. The OCP current must be considered the output component de-rating.  $V_r/I_{peak}/I_f$  of diode shall meet 90% of spec rating. The voltage and current rating for Dynamic/output short/input on off of all component  $\leq 100\%$  of the rated specification. Main switch MOSFET voltage de-rating  $\leq 90\%$  of the rated specification at steady status, and  $\leq 100\%$  of the rated specification at transient status.

5. Transformer and Inductor:

Transformer and Inductor core and coil temperature shall not exceed 110 °C and 80% of rated temperature ambient of 50 °C.

The core/junction temperature of all other components at all load condition, all input voltage range, and ambient of 55 °C shall not exceed 110 °C(130 °C max) and 150 °C(175 °C max) , and the thermal rating must be less than 80% rated specification.



The component thermal shall not reach its max specification rating while the power supply OTP/OCF trips due to the excessive heat in the all load/input voltage condition.

6. Component select requirements:

For PFC booster:  $V_{ds} \geq 600V$ .

For main switching MOSFET  $V_{ds} \geq 600V$ ; (full/half bridge or double forward topology).

For auxiliary switching MOSFET  $V_{ds} \geq 800V$  for single forward or Flyback topology, and the MOSFET must be separated from switching controller, so the TOP switch or Tiny switch shall be prohibited.

Bulk cap: The max voltage of  $\geq 450V$ . Temperature is 105 °C.

To meet 5 years life time, the Basic life  $L_o$  of bulk capacitor must be higher than 3000Hrs. And it is acceptable that the supplier must provide the evidence to ensure the life time meet 5 years by the calculating formula if the Basic life  $L_o$  is less than 3000Hrs.

7. MOV / Spark gap:

MOV/spark gap voltage must be up to 300Vrms if the MOV or spark gap is used. The voltage of other primary side components must also suffer up to 300Vrms.

8. The board material (PWB) shall be rated 130 °C minimum. And the surface temperature shall not exceed 100 °C.

## 15.0 SOFTWARE

### 15.1 PMBUS Communication

The  $V_{cc}$  of MCU in PSU is 4.5v, the system can communicate with PMBus1.2 protocol or I2C protocol. The PSU output terminal has two signals, one is SCL (clock bus), The other is SDA (data bus), and The communication rate is 100KHz. There is no pull-up resistance inside PSU on The I2C bus.

The system can connect different resistors in the Address signal(A/D5) to get different communication addresses of I2C. The pull-down resistance of the Address signal(A/D5) within the power supply is10K, The pull-up resistor on the system side can be set according to the Table26 I2C address.

Table26. I2C Address

Address signal (A/D5)	I2C Address
2.3~2.7V	74h



2.8~3.2V	76h
1.3~1.7V or 3.3~3.7V	78h
1.8~2.2V or 3.8~4.2V	7Ah

## 15.2 Software Data Format

Linear Data Formats:

The Linear Data Format is a two byte value with: An 11 bit, two’s complement mantissa and A 5 bit, two’s complement exponent (scaling factor). The format of the two data bytes is illustrated in below Figure.

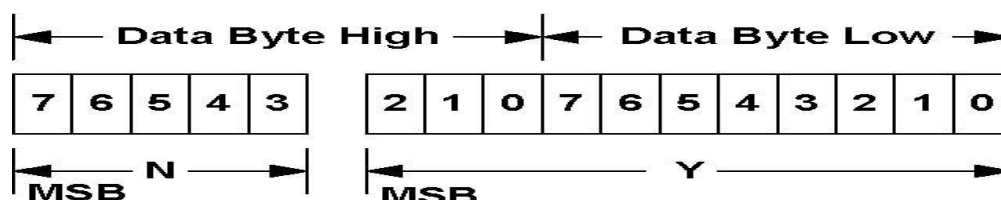

The relation between Y, N and the “real world” value is:  $X = Y \cdot 2^N$ .

Where, as described below:

X is the “real world” value being communicated.

Y is an 11 bit, two’s complement integer.

N is a 5 bit, two’s complement integer.

Devices that use the linear format must accept and be able to process any value of N.

## 15.3 Status Command

Table27. STATUS\_WORD Command (For Power module)

Byte	Bit	Status Bit Name	Meaning	Support
Low	7	BUSY	A fault was declared because the device was busy and unable to respond.	No
	6	OFF	This bit is asserted if the unit is not providing power to the output, regardless of the reason, including simply not being enabled.	Yes
	5	VOUT_OV	An output over voltage fault has occurred	Yes





	4	IOUT_OC	An output over current fault has occurred	Yes
	3	VIN_UV	An input under voltage fault has occurred	Yes
	2	TEMPER- ATURE	A temperature fault or warning has occurred	Yes
	1	CML	A communications, memory or logic fault has occurred	No
	0	NONE OF THE ABOVE	A fault or warning not listed in bits [7:1] of this byte has occurred	Yes
High	7	VOUT	An output voltage fault or warning has occurred	Yes
	6	IOUT/POUT	An output current or output power fault or warning has occurred	Yes
	5	INPUT	An input voltage, input current, or input power fault or warning has occurred	Yes
	4	MFR	A manufacturer specific fault or warning has occurred	Yes
	3	POWER_ GOOD#	The POWER_GOOD signal, if present, is negated	Yes
	2	FANS	A fan or airflow fault or warning has occurred	Yes
	1	OTHER	A bit in STATUS_OTHER is set	No
	0	UNKNOWN	A fault type not given in bits [15:1] of the STATUS_WORD has been detected	No

**Table28. STATUS\_VOUT Command**

Bit	Meaning	Support
7	VOUT Over voltage Fault	Yes
6	VOUT Over voltage Warning	Yes
5	VOUT Under voltage Warning	Yes
4	VOUT Under voltage Fault	Yes
3	VOUT_MAX Warning (An attempt has been made to set the output voltage to value higher than allowed by the VOUT_MAX command)	No
2	TON_MAX_FAULT	No
1	TOFF_MAX Warning	No



0	VOUT Tracking Error	No
---	---------------------	----

**Table29. STATUS\_IOUT Command**

Bit	Meaning	Support
7	IOUT Over current Fault	Yes
6	IOUT Over current And Low Voltage Shutdown Fault	No
5	IOUT Over current Warning	Yes
4	IOUT Undercurrent Fault	No
3	Current Share Fault	No
2	Power Limiting	No
1	POUT Overpower Fault	No
0	POUT Overpower Warning	No

**Table30. STATUS\_INPUT Command**

Bit	Meaning	Support
7	VIN Over voltage Fault	No
6	VIN Over voltage Warning	No
5	VIN Under voltage Warning	No
4	VIN Under voltage Fault	Yes
3	Unit Off For Insufficient Input Voltage	No
2	IIN Over current Fault	No
1	IIN Over current Warning	No
0	PIN Overpower Warning	No

**Table31. STATUS\_TEMPERATURE Command**

Bit	Meaning	Support
7	Over temperature Fault	Yes
6	Over temperature Warning	Yes
5	Under temperature Warnings	No
4	Under temperature Fault	No
3	Reserved	
2	Reserved	
1	Reserved	



0	Reserved	
---	----------	--

**Table32. STATUS\_FAN\_1\_2 Command**

Bit	Meaning	Support
7	Fan 1 Fault	Yes
6	Fan 2 Fault	No
5	Fan 1 Warning	Yes
4	Fan 2 Warning	No
3	Fan 1 Speed Overridden	No
2	Fan 2 Speed Overridden	No
1	Airflow Fault	No
0	Airflow Warning	No

**Table33. STATUS\_OTHER Command**

Bit	Meaning	Support
7	Reserved	No
6	Reserved	No
5	Input A Fuse Or Circuit Breaker Fault	No
4	Input B Fuse Or Circuit Breaker Fault	No
3	Input A Oring Device Fault	No
2	Input B Oring Device Fault	No
1	Output Oring Device Fault	No
0	Reserved	No

## 15.4 Supported Command

**Table34.**

CMD Code	Name	Type	Bytes	Conditions
03h	CLEAR_FAULTS	Send Byte	0	
07h	Power module READ_5Vsb_V_I	Block Read	4+1	5vsb voltage, current, status_5vsb
19h	CAPABILITY	Read Byte	1	Value 0x10
78h	STATUS_BYTE (Also Is The Lower Byte Of	Read Byte	1	



**ASPOWER**

深圳欧陆通电子股份有限公司

	STATUS_WORD)			
79h	STATUS_WORD	Read Word	2	
7Ah	STATUS_VOUT	Read Byte	1	
7Bh	STATUS_IOUT	Read Byte	1	
7Dh	STATUS_TEMPERATURE	Read Byte	1	
80h	STATUS_MFR_SPECIFIC	Read Byte	1	
81h	STATUS_FANS_1_2	Read Byte	1	
8Bh	READ_12VOUT	Read Word	2	
8Ch	READ_IOUT(12V)	Read Word	2	
8Dh	READ_TEMPERATURE_1	Read Word	2	
90h	READ_FAN_SPEED_1	Read Word	2	Rpm value
96h	READ_POUT	Read Word	2	
98h	PMBUS_REVISION	Read Byte	1	V1.2
99h	MFR_ID	Read Block	Variable	See MFR Data table
9Ah	MFR_MODEL	Read Block	Variable	See MFR Data table
9Bh	MFR_REVISION	Read Block	Variable	See MFR Data table
A0h	MFR_VIN_MIN	Read Word	2	See MFR Data table
A1h	MFR_VIN_MAX	Read Word	2	See MFR Data table
A4h	MFR_VOUT_MIN	Read Word	2	See MFR Data table
A5h	MFR_VOUT_MAX	Read Word	2	See MFR Data table
A6h	MFR_IOUT_MAX	Read Word	2	See MFR Data table
A7h	MFR_POUT_MAX	Read Word	2	See MFR Data table
A8h	MFR_TAMBIENT_MAX	Read Word	2	See MFR Data table
A9h	MFR_TAMBIENT_MIN	Read Word	2	See MFR Data table

**Table35. MFR Data table**

CMD Code	Name	Conditions
99h	MFR_ID	“ASPOWER”
9Ah	MFR_MODEL	“U1A-P10650-DRB”
9Bh	MFR_REVISION	



**ASPOWER**

深圳欧陆通电子股份有限公司

---

A0h	MFR_VIN_MIN	90V
A1h	MFR_VIN_MAX	264V
A4h	MFR_VOUT_MIN	11.4V
A5h	MFR_VOUT_MAX	12.6V
A6h	MFR_IOUT_MAX	54A
A7h	MFR_POUT_MAX	650W
A8h	MFR_TAMBIENT_MAX	50°C
A9h	MFR_TAMBIENT_MIN	0°C

